



**Ultrafryer Systems, Inc.**  
*F-P30-18 High Efficiency/  
 High Production Gas Fryer*

Project \_\_\_\_\_  
 Item \_\_\_\_\_  
 Quantity \_\_\_\_\_  
 Approval \_\_\_\_\_  
 Date \_\_\_\_\_



**Standard Features:**

- High efficiency Par-3 heat exchanger
- 75 lb shortening capacity
- Dial thermostat inside cabinet
- Stainless steel vat, cabinet and frame
- Pilotless electronic ignition
- Heavy duty casters with front locking brakes
- 2 baskets
- Drain cleaning rod and vat cleaning brush

**Options and Accessories:**

- 2 product Ultrastat computer controller
- 10 product Ultrastat computer controller
- Vat joiner strips to join 2 or more fryers
- Splash guard (left side and/or right side)
- 3/4" x 48" gas quick disconnect
- Vat cover

**Specifications**

*Designed to meet high production frying needs with low energy cost*

The Ultrafryer Systems F-P30-18 is a floor model fryer designed to meet high volume frying needs while providing the maximum in energy savings. The F-P30-18 has a cooking efficiency of 61.1%. The fast recovery of the Ultrafryer® F-P30-18 shortens cooking time and reduces shortening absorption. Pilot-less electronic ignition and dial thermostat allow for accurate temperature control and ease of operation. The phased array heat exchanger provides a large surface area and extended path of travel for the combustible gases ensuring fast recovery, uniform heat distribution and low exhaust temperatures of 500 degrees or less.

The F-P30-18 cabinet and door are fabricated from high quality stainless steel to ensure a long service life.

The F-P30-18 is equipped with a screw-in front drain pipe for easy shortening filtration and/or disposal.

The F-P30-18 has a maximum shortening capacity of 75 lbs.(36 liters). The cooking zone is 18" x 18" (457mm X 457mm) with shakezone and a 7" drainboard.

The F-P30-18 is rated 110,000 BTU/h.



**F-P30-18  
 75 lb. Gas Fryer**

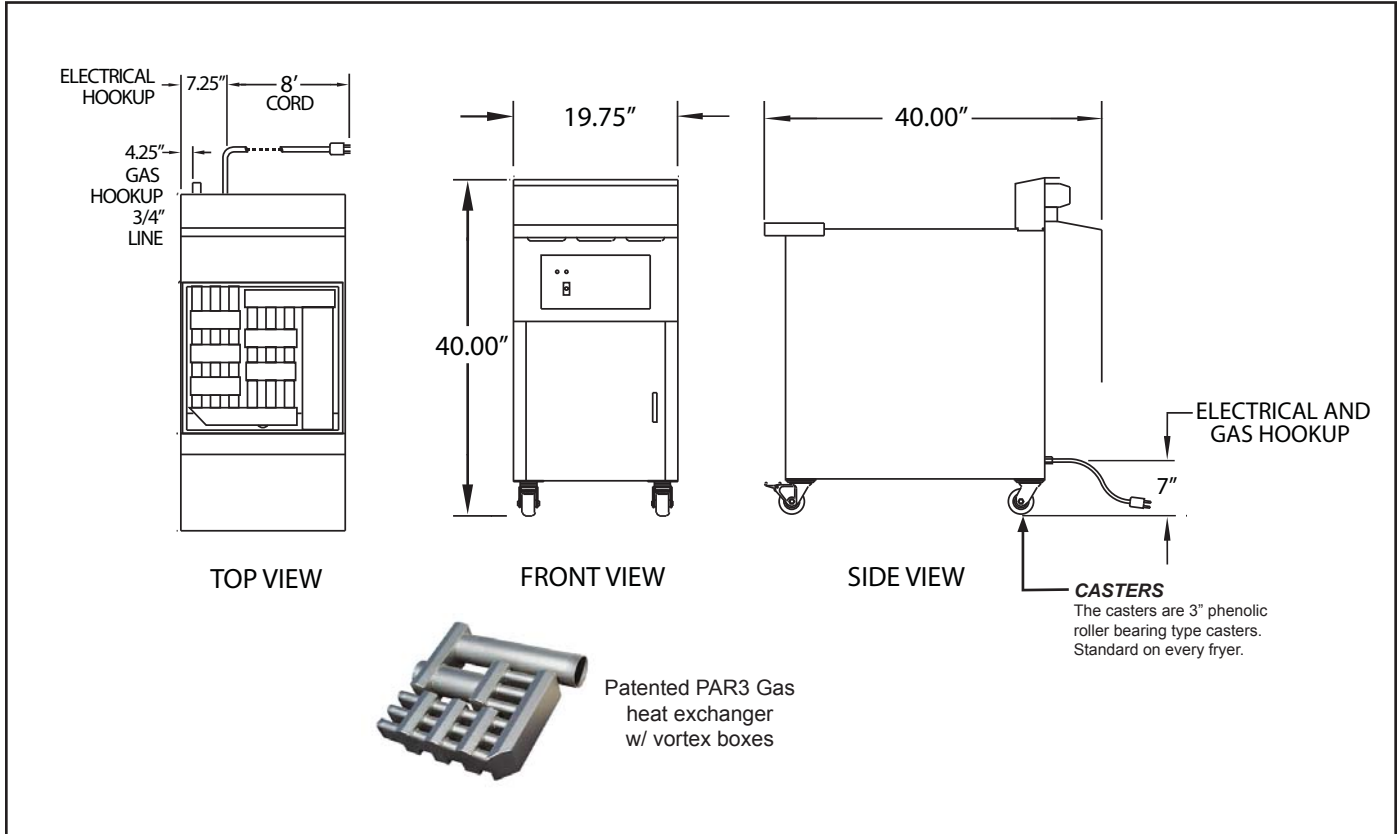

Dimensions - inches (mm)

Model No.	Shortening Capacity	Overall Size			Drain Height	Net Weight	Shipping Info
		Height	Depth	Width			
F-P30-18	75 lbs. (36 liters)	40" (1016)	40" (1016)	19 3/4" (502)	18" (458)	275 lbs. (125 kgs)	F.O.B. Factory San Antonio, Texas

**ELECTRICAL AND GAS REQUIREMENTS FOR OPERATING SYSTEM**

120 V, 60 HZ, 1 phase, 3.0 amps.

**GAS INLET PRESSURE PER VAT REQUIRED:**

7" water column natural gas

14" water column propane/butane

**PERFORMANCE SPECIFICATIONS**

Determined in accordance with ASTM F 1361-91 Standard Test Method for the performance of open deep fat fryers:

Nominal Vat Size	Energy Input Rating	Shortening Capacity
18"	110,000 BTU's	75 lbs.

Due to continuing engineering development and improvements, specifications are subject to change without notice.  
 © October 12, 2010 Ultrafryer Systems, Inc.