



Ultrafryer Systems, Inc.
Ultrawarmer®

Project _____
Item _____
Quantity _____
Approval _____
Date _____



Standard Features:

- Heated air holding
- Large dividable holding area
- Stainless steel construction
- Open top construction
- Removable holding bin
- Components located in back panel

Specifications

The Ultrawarmer® Food Holding Station has been designed to hold a variety of fried products. The Ultrawarmer® directs heated air over and under and through fried foods keeping food at the perfect serving temperature while preserving the products surface crispness and moisture content ensuring freshness and quality for your customer.

The Ultrawarmer's large holding area can be divided to fit your specific product mix. Open top construction makes transfer of products from the fryer efficient and serving of products fast and easy.

The Ultrawarmer® features stainless steel construction and is designed with longevity and ease of cleaning in mind. All components are located in the back panel to prevent grease contamination. The holding bin is easily removable for cleaning and the unit features a slide out debris collector to ease cleaning throughout the day.

The Ultrawarmer® is backed by one year-limited warranty.



Ultrawarmer®

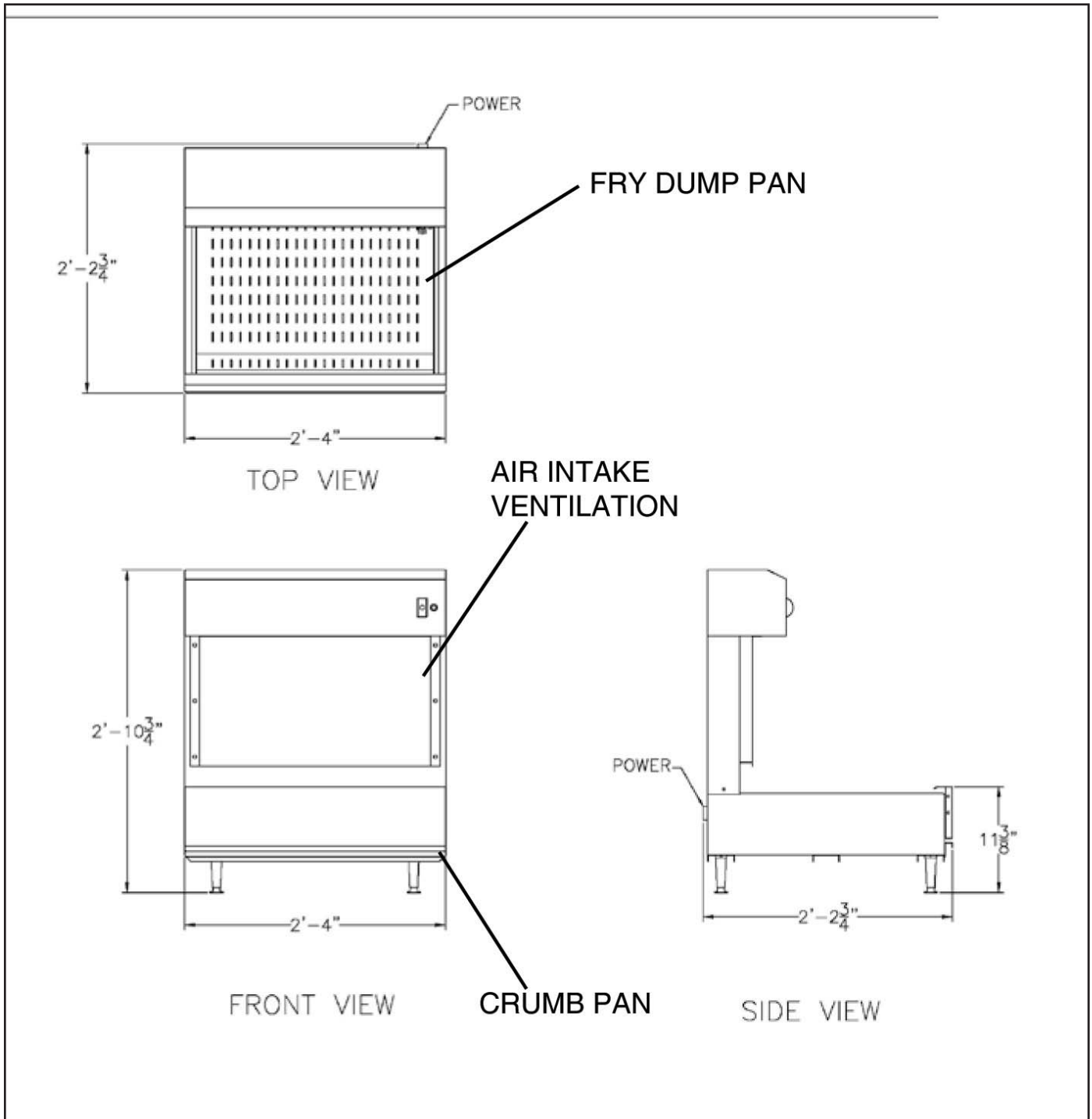

ELECTRICAL REQUIREMENTS FOR OPERATING SYSTEM

Control Voltage: 208 V, 60 HZ, 1 phase, 23 amps.

Due to continuing engineering development and improvements, specifications are subject to change without notice.
© February 2, 2009 Ultrafryer Systems, Inc.